

IF A COMPANY (Complete this Section)

Company

Name:.....

Registered

Address:.....

.....**Phone:**.....

Business License Number:.....

DETAILS OF DIRECTORS:

Name:.....

Private

Address:.....

Phone:.....

Name:.....

Private

Address:.....

Phone:.....

Name:.....

Private

Address:.....

Phone:.....

BANK DETAILS:

Bank:.....**Branch:**.....

Account Name:.....

Account Number:.....

Monthly Credit Applied For:.....

Anticipated Annual Spend A\$:.....

BUSINESS REFERENCES:

Name:.....

Address:.....

Phone:..... **Fax:**.....

Monthly Spend A\$.....

Name:.....

Address:.....

Phone:..... **Fax:**.....

Monthly Spend A\$.....

Name:.....

Address:.....

Phone:..... **Fax:**.....

Monthly Spend A\$.....

PLEASE READ CAREFULLY BEFORE SIGNING

I/We the undersigned hereby request that TIC (Retail Accessories) supply goods to me in consideration of TIC (Retail Accessories) agreeing to do so. I/We hereby jointly and severally warrant to and covenant with TIC (Retail Accessories) as follows;

1. That all information contained herein is true and correct in every particular and that all material facts have been disclosed to TIC (Retail Accessories).
2. That payments for all goods supplied by TIC (Retail Accessories) will be made strictly in accordance with the trading terms applicable from time to time.
3. If the applicant is a company then provision of a trading account pursuant to this application is subject to and conditional upon the applicant's directors executing a Guarantee in the form approved.
4. The undersigned and any director or principal of the applicant have never been made bankrupt and are solvent and are able to pay their debts as they fall due and have not made any compromise or arrangement with their creditors and no application has been made or proposed to a summon meeting of their creditors or any class of them.
5. That the applicant (if a corporation) is solvent and able to pay its debts as they fall due and is not in liquidation or being wound up and no meeting has been called or resolution has been passed or order made for such purposes and no Receiver or Receiver Manager has been appointed in respect of the applicant and the applicant has not made any compromise or arrangement with its creditors or any class of them and no application has been proposed or made to any court for an order summoning a meeting of its creditors or any class of them.
6. That the applicant hereby acknowledges receipt for TIC (Retail Accessories) Terms of Trade, as they presently exist.

^^

Dated the:..... day of.....20.....

SOLE TRADER (SIGNATURE):.....

PARTNERS (SIGNATURE):.....

THE COMMON SEAL of)
was hereunto affixed)
in accordance with its Articles of)
Association in the presence of)

.....Director

.....Secretary

TIC (Retail Accessories) Pty Ltd.
51 Regan Street, St. Albans, Victoria, Australia 3021

Your Authorised TIC Webpage Password

IN CONSIDERATION of you having agreed or agreeing to sell goods or provide services or extend credit to the party named in the Schedule hereto as the debtor (herein after called "the debtor" we, the parties named in the Schedule hereto as he Guarantors JOINTLY AND SEVERALLY GUARANTEE the due and punctual payment to you by the debtor of all monies now and hereafter payable to the debtor to you on any account whosoever whether such sale, provision or extension shall have occurred or been made before or after the execution of this instrument and whether or not the said agreement to sell goods, provide services or extend credit, may be or become void or voidable or unenforceable by law. WE JOINTLY AND SEVERALLY INDEMINIFY you against all loss and damage suffered by you by reason of a failure of the debtor duly to perform any obligation on its part arising out of or in connection with such sale, provision or extension AND WE EXPRESSLY ACKNOWLEDGE AND DECLARE that this Guarantee is given upon the following conditions:

1. The certificate of your Secretary, Credit Manager or Solicitors for the time being stating the amount or amounts due and owing to you by the debtor in relation to such sale, provision or extension shall be conclusive evidence of the indebtedness of the debtor to you as the date stated in such certificate.
2. Our liability to you hereafter shall not be affected by time or any other indulgence granted to you by the debtor or by modification or variation in the terms of sale, provision or extension. You may at such time as you think fit cease to sell goods to or provide services for or extend credit to the debtor.
3. The guarantee hereby given shall be a continuing guarantee and shall bind our executors and administrators.
4. Any demand on us hereunder may be duly made if it is in writing signed by your Secretary, Credit Manager or Solicitors and is given to or left for us at or posted to one of our addresses set out as below or to such other addresses as we may from time to time notify you in writing, PROVIDED THAT it shall not be a condition precedent to the exercise of your rights against us hereunder that any demand or notice will be given to us.
5. Except where the context forbids words herein importing the plural shall include the singular and vice versa.
6. Until you have received 100 cents in the dollar in respect of the Guarantee obligations the Guarantor shall not be entitled either directly or indirectly receive the benefit from the administration of the affairs of the debtor in insolvency resulting from the lodging of any proof or make nay claim in respect thereof in competition with you so as to diminish any amount that but for such dividend or other payment that you may receive shall not prejudice your right to recover so much of the guaranteed amounts as have not been paid to you.
7. No monies received by you to the creditor of the debtor and for which you may in any administration in insolvency of the affairs as the debtor be obliged to account to any liquidator, official manager, trustee in bankruptcy may in your discretion be received by you discharge or diminish our liability hereunder.

Conditions of Sale

Interpretation

1. In these conditions:
 - 'Seller' means [Tic (Retail Accessories) Pty Ltd] which is the seller of the goods.
 - 'Buyer' means the purchaser of the goods specified overleaf.
 - 'Goods' means the products and, if any, services specified overleaf.Nothing in these conditions shall be read or applied so as to exclude, restrict or modify or have the effect of excluding, restricting or modifying any condition, warranty, guarantee, right or remedy implied by law (including the Trade Practices Act 1974) and which by law cannot be excluded, restricted or modified.

General

2. These conditions (which shall only be waived in writing signed by the seller) shall prevail over all conditions of the buyer's order to the extent of any inconsistency.

Important note: A number of garment hangers, accessories and supporting devices are the subject of Intellectual Property Rights owned by TIC Group Pty Ltd. and/or its affiliates. Any breach of these rights may be the subject of legal action.

Disclaimer: Suppliers have a duty of care to ensure hangers and accessories selected from the TIC range can withstand the particular transport, distribution and handling environments they will be subjected to. Please contact TIC if you require assistance with the selection of hangers or accessories.

Terms of sale

3. The goods and all other products sold by seller are sold on these terms and conditions.

Seller's quotations

4. Unless previously withdrawn, seller's quotations are open for acceptance within the period stated in them or, when no period is so stated, within 30 days only after its date. The seller reserves the right to refuse any order based on this quotation within 7 days after the receipt of the order.

Packing

5. The cost of any special packing and packing materials used in relation to the goods are at the buyer's expense notwithstanding that such cost may have been omitted from any quotation.

Shortage

6. The buyer waives any claim for shortage of any goods delivered if a claim in respect for short delivery has not been lodged with the seller within seven (7) days from the date of receipt of goods by the buyer.

Delivery

7. (a) The delivery times made known to the buyer are estimates only and the seller is not be liable for late delivery or non-delivery.
 - (b) The seller is not be liable for any loss, damage or delay occasioned to the buyer or its customers arising from late or non-delivery or late installation of the goods.
 - (c) The seller may at its option deliver the goods to the buyer in any number of instalments unless there is an endorsement overleaf to the effect that the buyer will not take delivery by instalments.
 - (d) If the seller delivers any of the goods by instalments, and any one of those instalments is defective for any reason:
 - (1) it is not a repudiation of the contract of sale formed by these conditions; and
 - (2) the defective instalment is a severable breach that gives rise only to a claim for compensation.

Loss or damage in transit

8. (a) The seller is not responsible to the buyer or any person claiming through the buyer for any loss or damage to goods in transit caused by any event of any kind by any person (whether or not the seller is legally responsible for the person who caused or contributed to that loss or damage).
 - (b) The seller must provide the buyer with such assistance as may be necessary to press claims on carriers so long as the buyer:
 - (1) has notified the seller and the carriers in writing immediately after loss or damage is discovered on receipt of goods; and
 - (2) lodges a claim for compensation on the carrier within three (3) days of the date of receipt of the goods.

Prices

9. (a) Unless otherwise stated all prices quoted by the seller are net, exclusive of Goods and Services Tax (GST).
 - (b) Prices quoted are those ruling at the date of issue of quotation and are based on rates of freight, insurance, customs duties, exchange, shipping expenses, sorting and stacking charges, cartage, rate of wates, cost of materials and other charges affecting the cost of production ruling on the date is made.
 - (c) If the seller makes any alterations to the price of the goods or to any of their inputs either before acceptance of

or during the currency of the contract, these alterations are for the buyer's account.

Payment

10. The purchase price in relation to goods is payable net and payment of the price of the goods must be made on or before thirty days from date of the delivery of the goods unless other terms of payment are expressly stated in these conditions in writing.

Rights in relation to goods

11. The seller reserves the following rights in relation to the goods until all accounts owed by the buyer to the seller are fully paid:

- (1) ownership of the goods;
- (2) to enter the buyer's premises (or the premises of any associated company or agent where the goods are located) without liability for trespass or any resulting damage and retake possession of the goods; and
- (3) to keep or resell any goods repossessed pursuant to (2) above.

If the goods are resold by the buyer, the buyer shall hold such part of the proceeds of any such sale as represents the invoice price of the goods sold in a separate identifiable account as the beneficial property of the seller and shall pay such amount to the seller upon request. Notwithstanding the provisions above the seller shall be entitled to maintain an action against the buyer for the purchase price and the risk of the goods shall pass to the buyer upon delivery.

Buyer's property

12. Any property of the buyer under the seller's possession, custody or control is completely at the buyer's risk as regards loss or damage caused to the property or by it.

Storage

13. The seller reserves the right to make a reasonable charge for storage if delivery instructions are not provided by the buyer within fourteen days of a request by the seller for such instructions. The parties agree that the seller may charge for storage from the first day after the seller requests the buyer to provide delivery instructions.

Returned goods

- 14. (a) The seller is not be under any duty to accept goods returned by the buyer and will do so only on terms to be agreed in writing in each individual case.
- (b) If the seller agrees to accept returned goods from the buyer under para (a) of this clause, the buyer must return the goods to the seller at the seller's place of business referred to at the head of these conditions.

Goods sold

15. All goods to be supplied by the seller to the buyer are as described on the purchase order agreed by the seller and the buyer and the description on such purchase order modified as so agreed prevails over all other descriptions including any specification or enquiry of the buyer.

Cancellation

16. No order may be cancelled except with consent in writing and on terms which will indemnify the seller against all losses.

Default

17. If the Buyer defaults in payment of any monies due to the Seller the Buyer shall at the option of the Seller pay to the Seller interest on the monies in respect of which default in payment has been made calculated at the daily rate being the rate prescribed from time to time pursuant to the Penalty Interest Rates Act 1983 plus 4% together with and in addition to all costs and expenses including legal costs on a solicitor/client basis incurred by the Seller in recovering from the Buyer monies due as a consequence of the default by the Buyer in payment of monies on the due date for payment.

Place of contract

- 18 (a) The contract for sale of the goods is made in the State of Victoria.
- (b) The parties submit all disputes arising between them to the courts of the State of Victoria and any court competent to hear appeals from those courts of first instance.

Signed _____ Position _____

Dated _____



HANGER INDEX

Category	Code	Colour	Description
Tops	TH40X	Black	250 mm Children's Upper Body
	TH41X	Black	300 mm Children's Upper Body
	TH42X	Black	350 mm Children's Upper Body
	TH43	Black	400 mm Adult's Upper Body
	TH45	Black	460 mm Adult's Upper Body
	TH46	Black	520mm Adult's Upper Body
	KN44	Black	420mm Adults' Knitwear
	KN47	Black	460 mm Adult's Knitwear
	AC67	Grey	Foam Sleeves
	SU65	Black	Suit Hanger
SU86	Black	Jacket Hanger	
Frame	FR78	Black	250 mm x 320mm
	FR79	Black	250 mm x 350mm
	FR80	Black	350mm x 430mm
	TP46	Black	400 mm x 280 mm & Height 370mm
Bottoms	PH54	Black	190mm Children's Lower Body Prong
	PH54L	Black	190mm Children's Lower Body Prong With Loop
	PH55	Black	260mm Children's Lower Body Prong
	PH55L	Black	260mm Children's Lower Body Prong With Loop
	FL57	Black	280mm Adult's Lower Body Fox Lock
	FL58	Black	310mm Adult's Lower Body Fox Lock
	FL59	Black	350mm Adult's Lower Body Fox Lock
	BH60	Black	210mm Children's Lower Body Clip
	BH64	Black	260mm Children's Lower Body Clip
	BH61	Black	280mm Children's Lower Body Clip
	BH61L	Black	280mm Children's Lower Body Clip With Loop
	BH62	Black	310mm Adult's Lower Body Clip
	BH63	Black	350mm Adult's Lower Body Clip
Access.	AC16	ASSTD	Garments Sizing Clip
	AC16	ASSTD	Garments Sizing Range
Lingerie	LH34 BL	Black	250mm Mens Brief
	LH34 CR	Crystal	250mm Ladies Brief
	LH35 BL	Black	200mm Childrens Brief
	BR32 CR	Crystal	285mm Bra Hanger
	BR33 CR	Crystal	335mm Bra Hanger
Access.	AC22	ASSTD	Lingerie Sizing Tabs
	AC22	ASSTD	Lingerie Sizing Range



HANGER INDEX

Category	Code	Colour	Description
Footwear	FW24	Black	115mm Thong Hanger
	FW23	Black	70mm Children's U End
	FW75	Black	120mm U End
	FW25	Black	170mm Multi Purpose
	FW77	Black	195mm Multi Purpose
	FW26	Black	215mm Multi Purpose
Access.	AC21	ASSTD	Footwear Sizing Tabs
	AC21	ASSTD	Footwear Sizing Range
Scarfe	SC27	Black	35mm Small
	SC28	Black	50mm Large
Access	AC65	Black	90x70mm Hook & Loop
	AC69	Black	152x70 mm Hook & Loop
	AC66	Black	250x70mm Hook & Loop
Price Lists			Price List Garment Hangers
			Price List Garment Hangers

Category • Children, Youth

Application • Shirts, Tops (assorted), Dresses, Knitwear, Jackets, Jump Suits, Overalls, Sleepwear, Spencers, Camisoles and Slips

C O D E

TH40X

TH41X

TH42X

Top Hanger

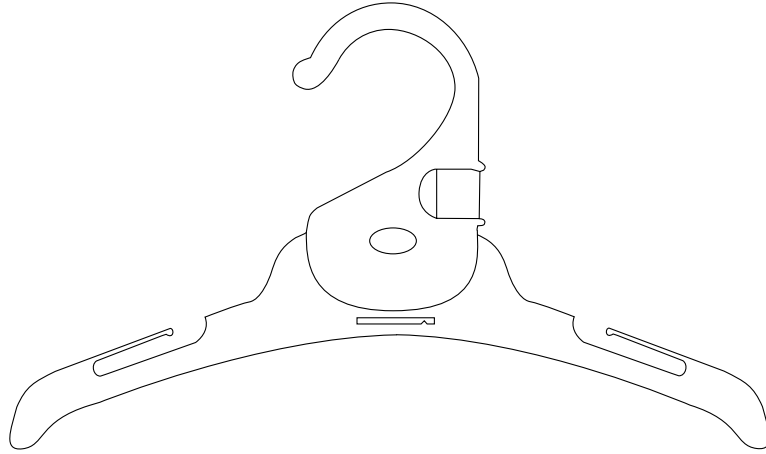

TH40X
250mm

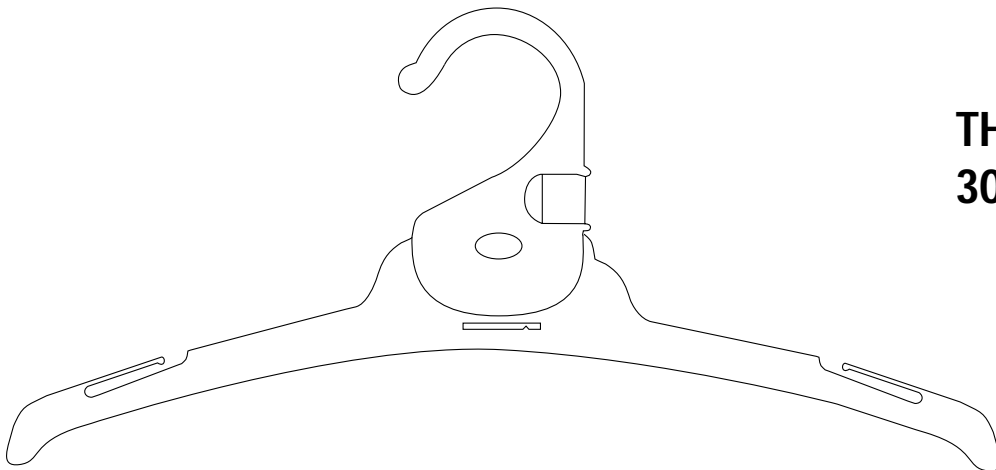

TH41X
300mm

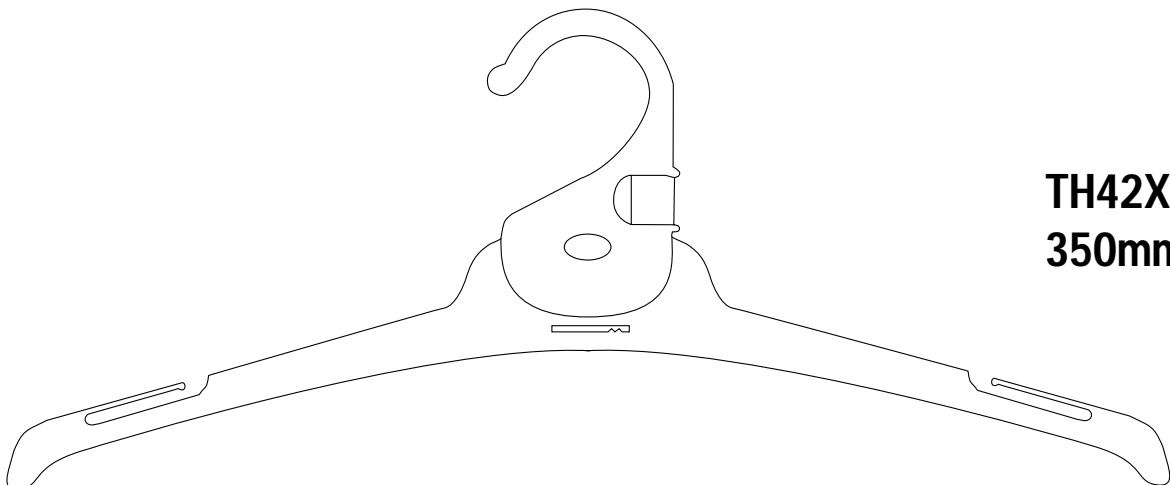

TH42X
350mm

C O D E

TH43

TH45

TH46

Top Hanger

Category • Children, Adult

Application • Shirts, Tops (assorted), Dresses, Lightweight Jackets, Pyjamas, Dressing Gowns, Spencers and Vests

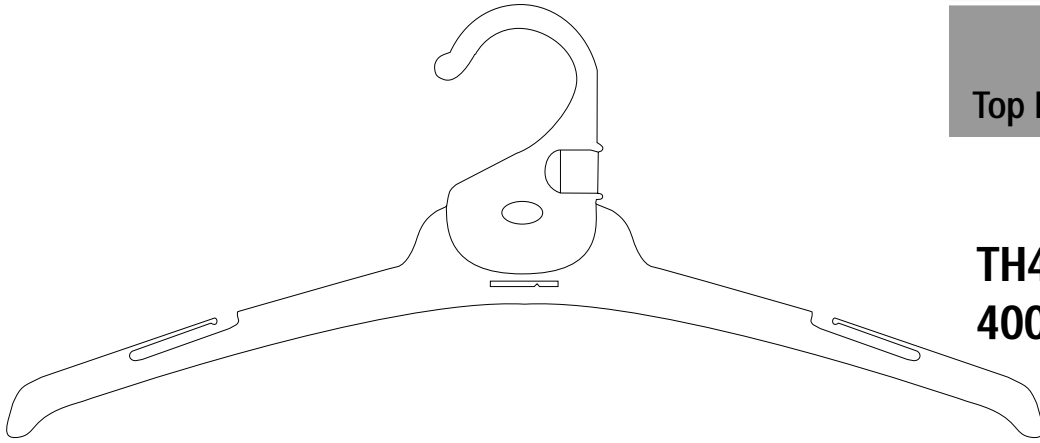

TH43
400mm

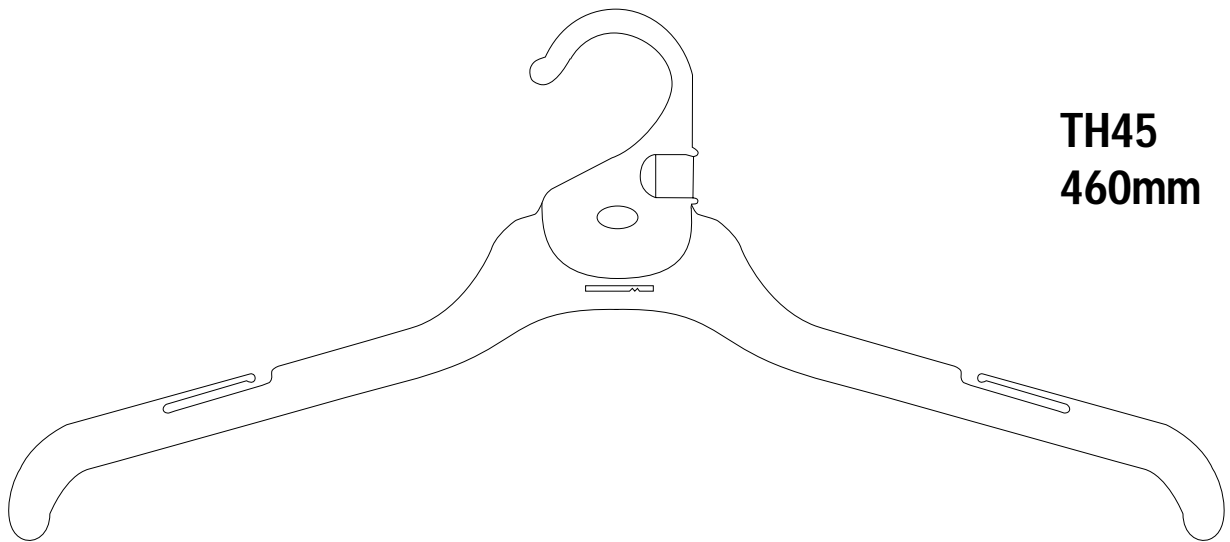

TH45
460mm

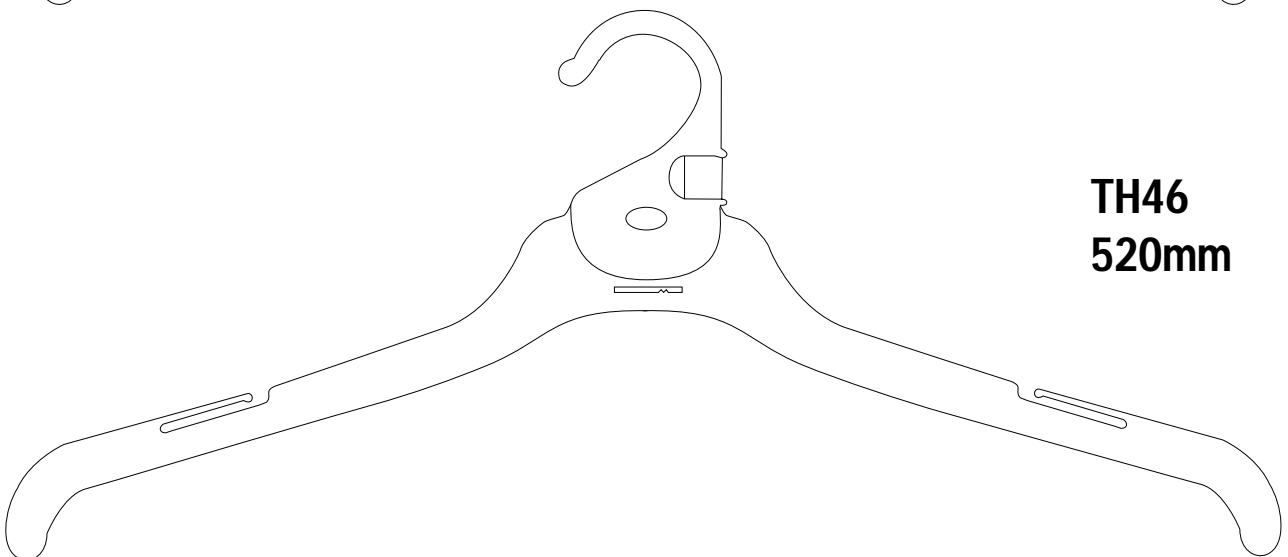

TH46
520mm

C O D E

Category • Adult / Youth

Application • Knitwear, Lightweight Jackets, Coats, Parkas
and Maternity Wear

KN44

KN47

Knitwear Hanger

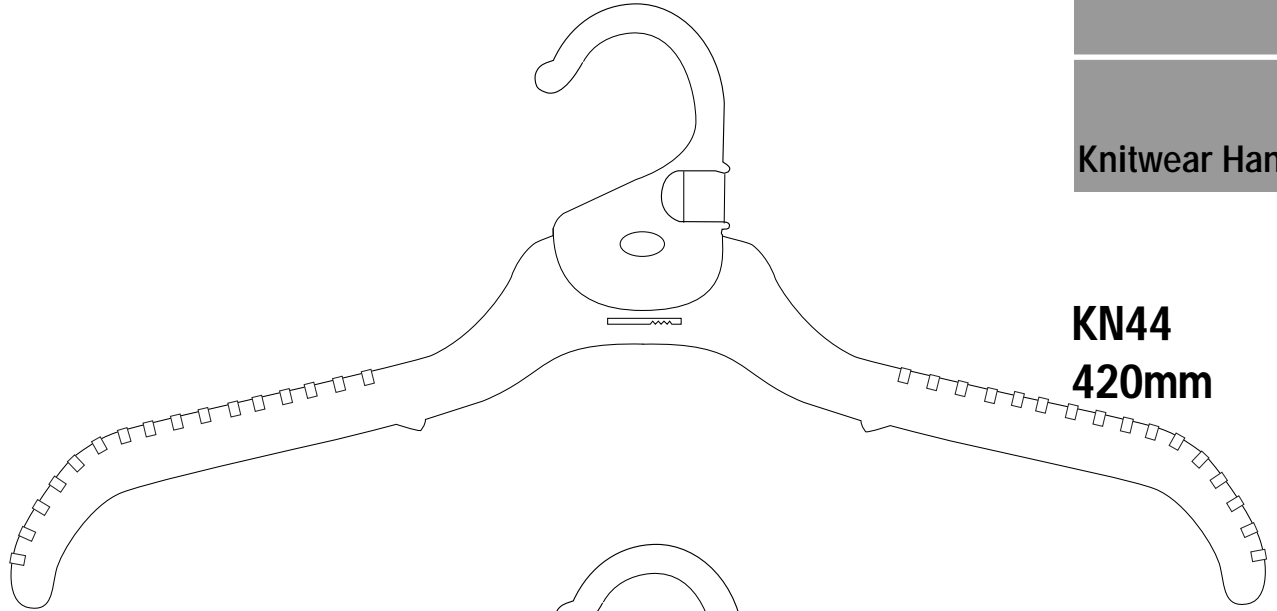

KN44
420mm

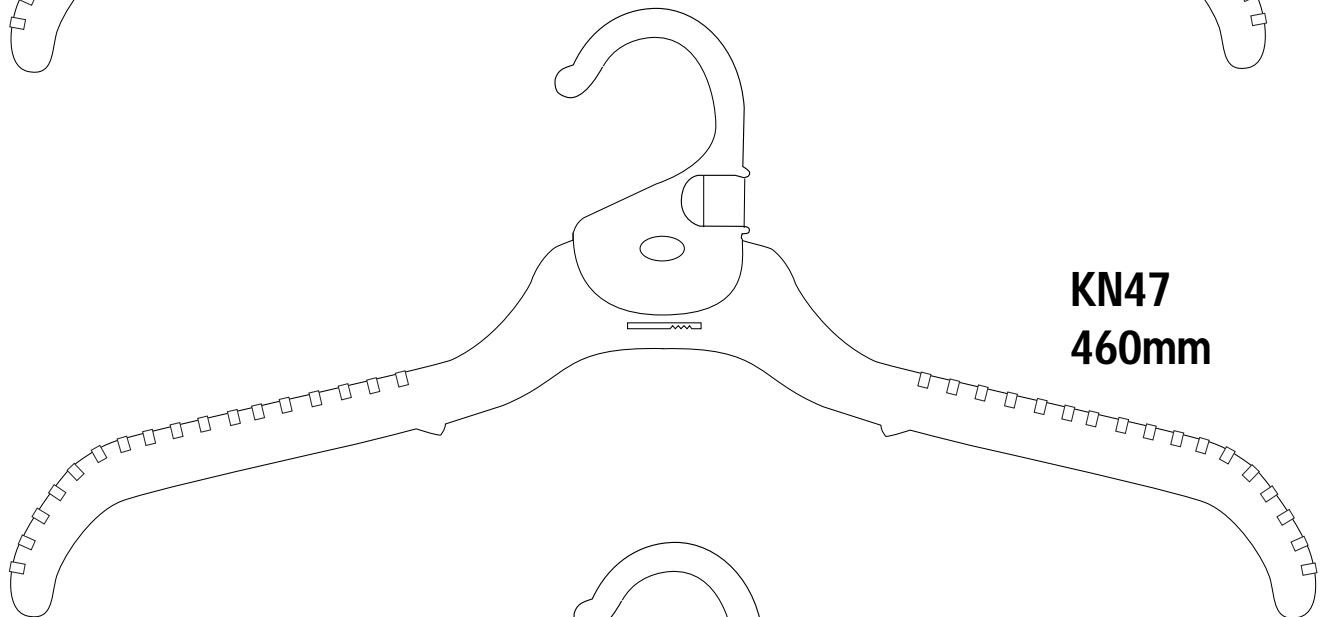

KN47
460mm

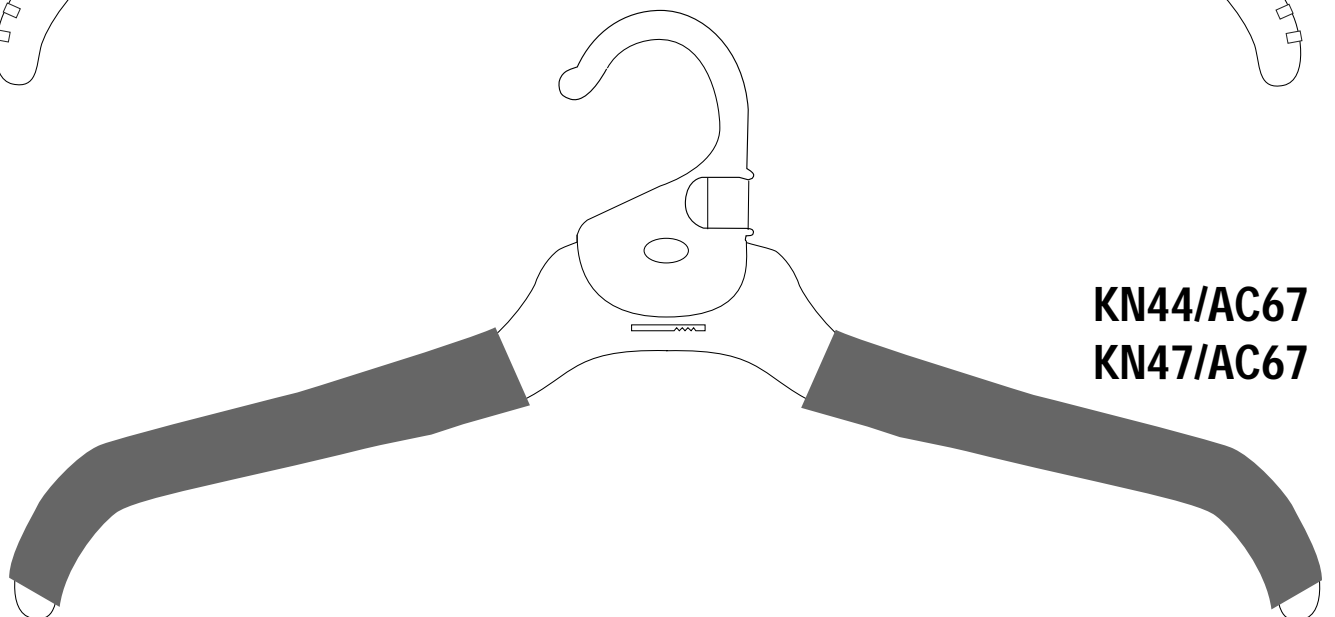

KN44/AC67
KN47/AC67

C O D E

AC67

Category • Adult

Application • For KN44 and KN47 Knitwear Hanger only

**Foam Sleeve
(Knitwear Hanger)**

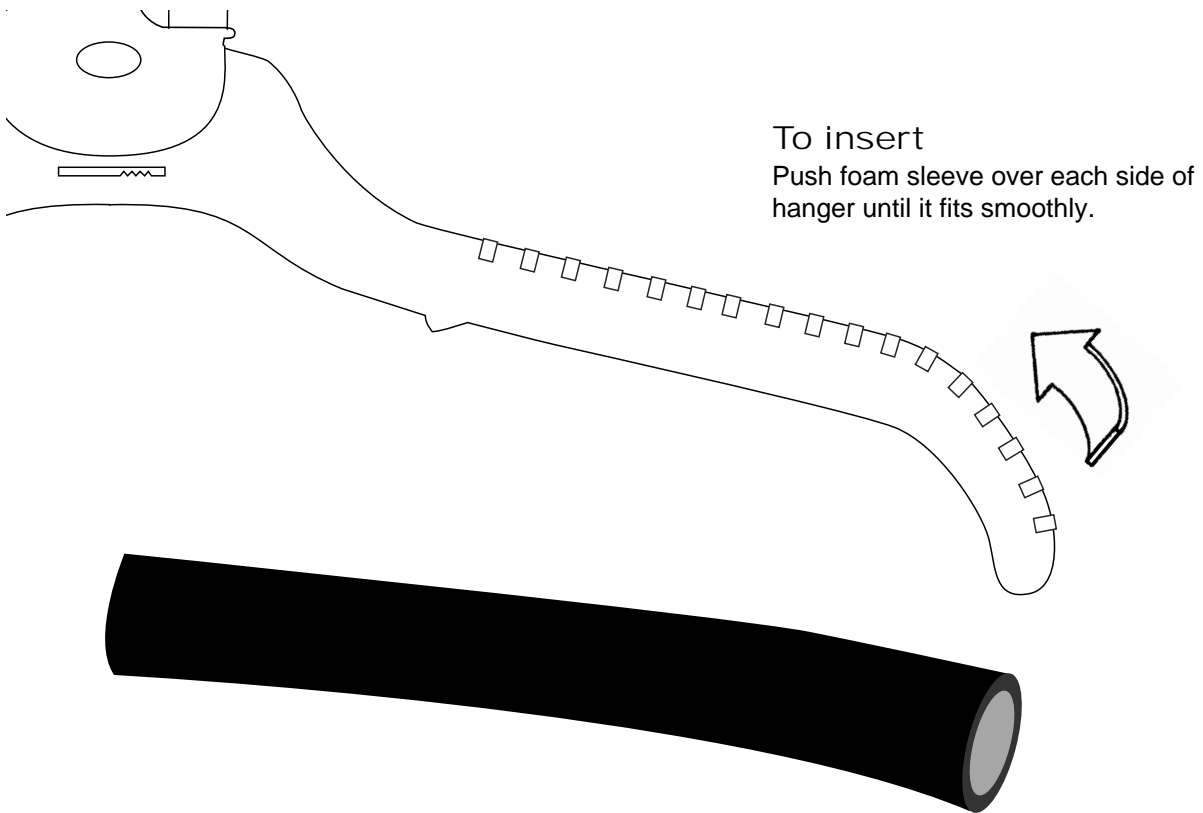

C O D E

SU65

SU86

460mm
Suit Hanger
and
Jacket Hanger

Category • Adult

Application • Jackets, Suits

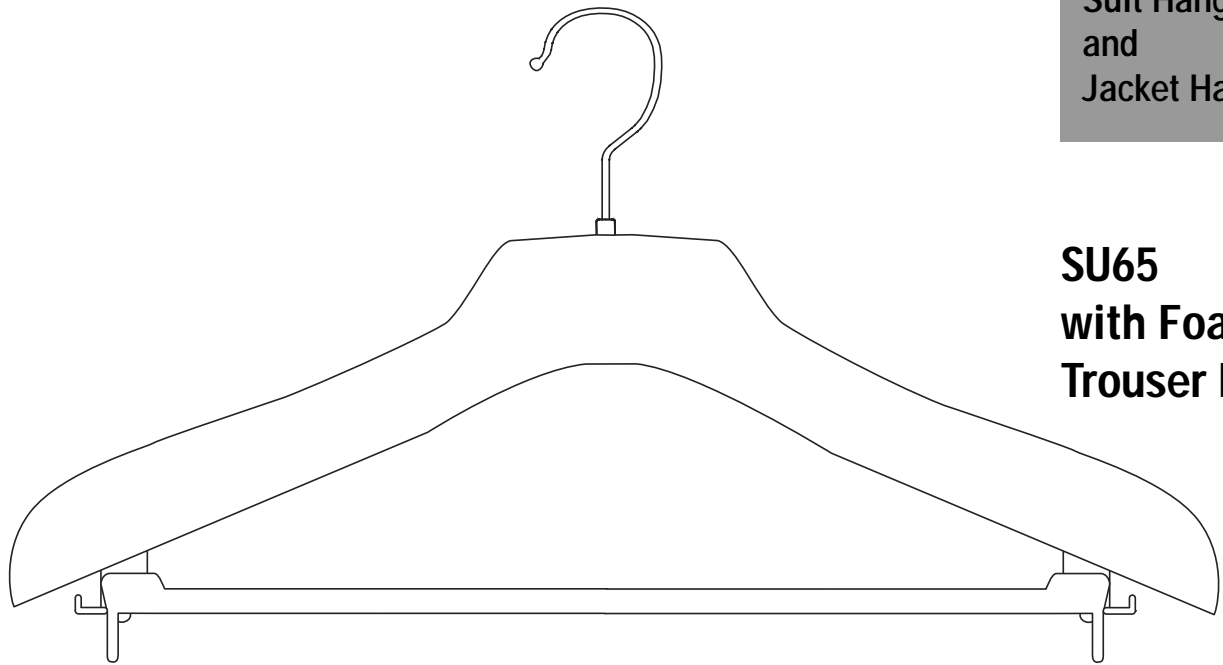

SU65
with Foam on
Trouser Bar

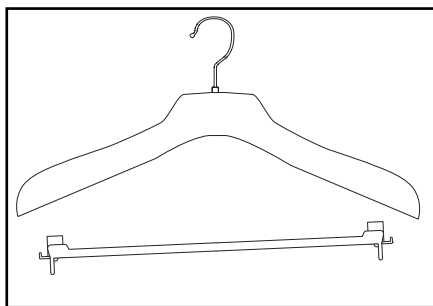

Removable
trouser bar

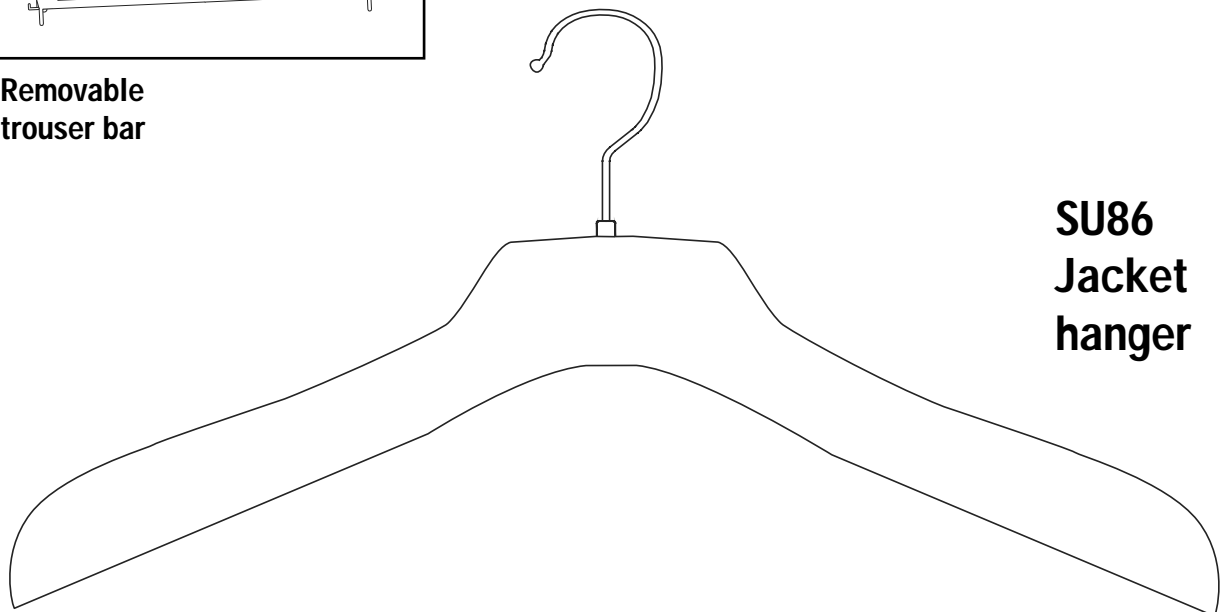

SU86
Jacket
hanger

C O D E

FR78

FR79

FR80

Frame Hanger

Category • Infant and Toddlers

Application • 2 Piece sets

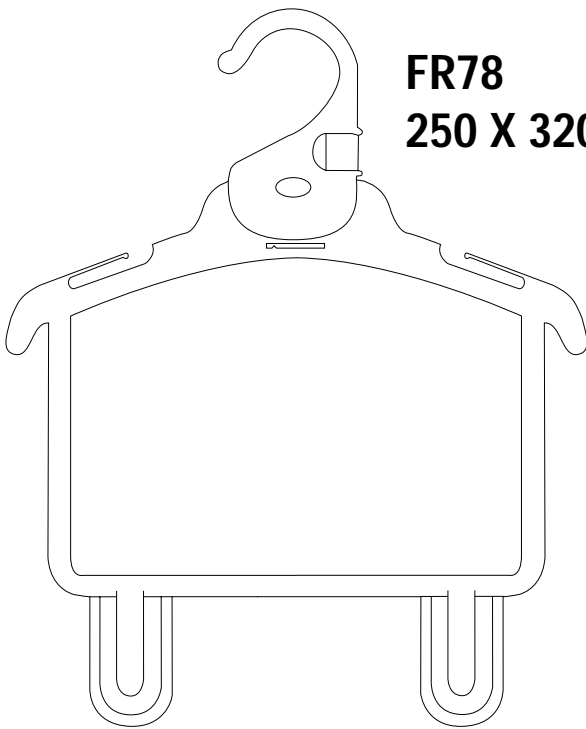

FR78
250 X 320mm

FR79
250 X 350mm

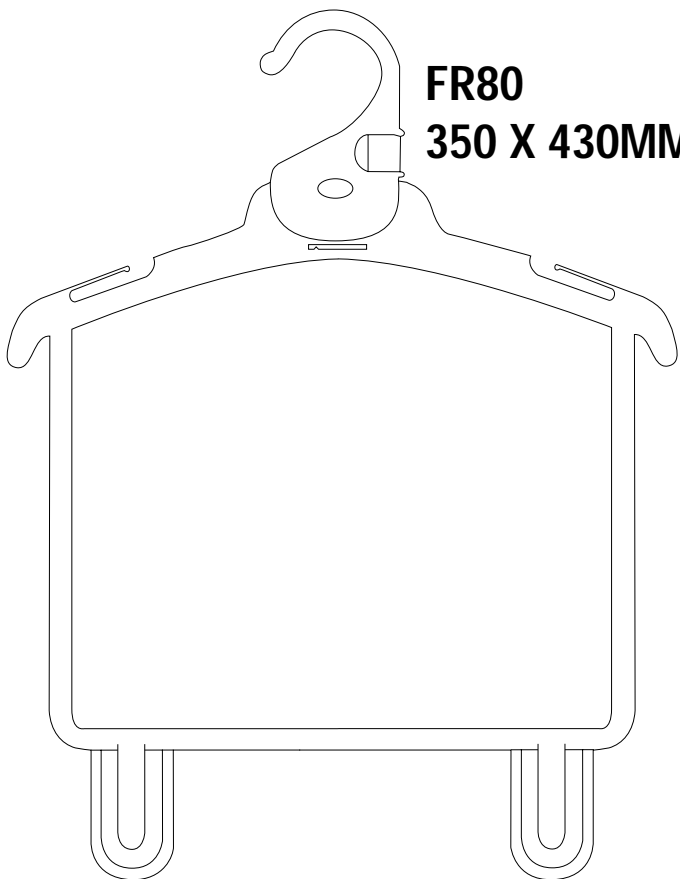
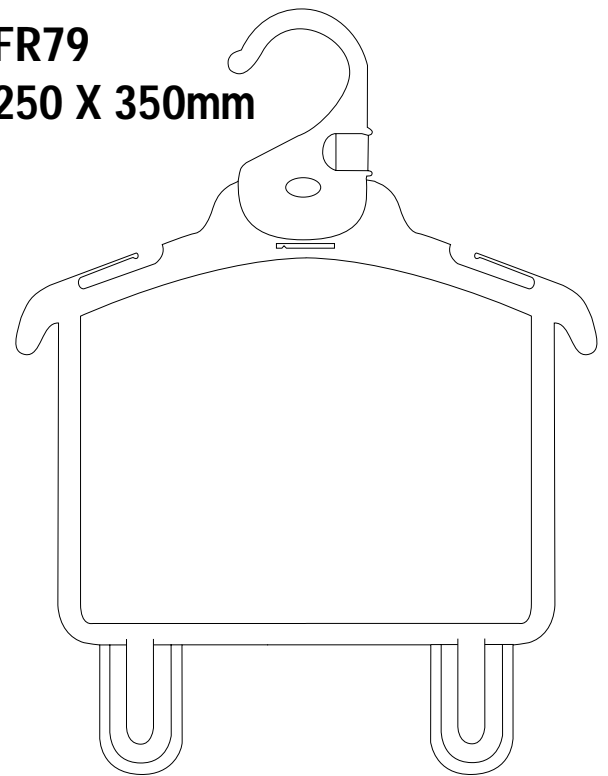

FR80
350 X 430MM

C O D E

TP46

Category • Adult

Application • 2 piece sets and Pyjamas

400 x 280mm
Top Hanger +
Bottom Hanger

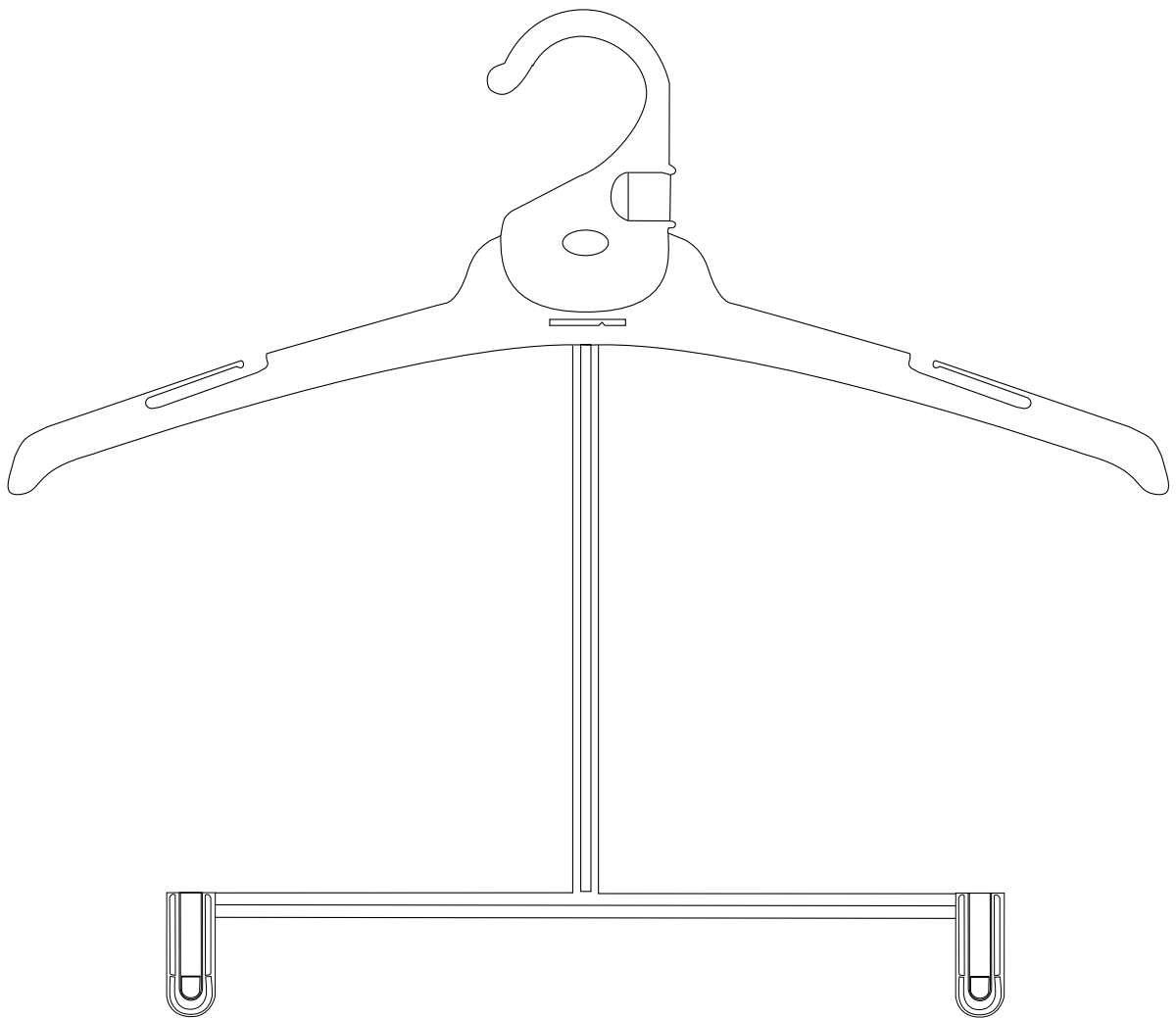

Category • Children, Adult

Application • Pants, Skirts, Shorts, and Sets

PH54

PH55

Bottom Hanger
- Prong

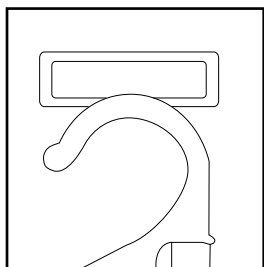

PH54L
with loop for
two piece sets

PH54
190mm

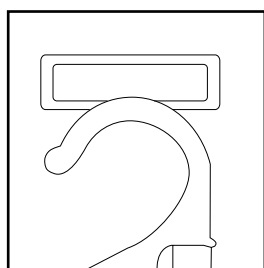
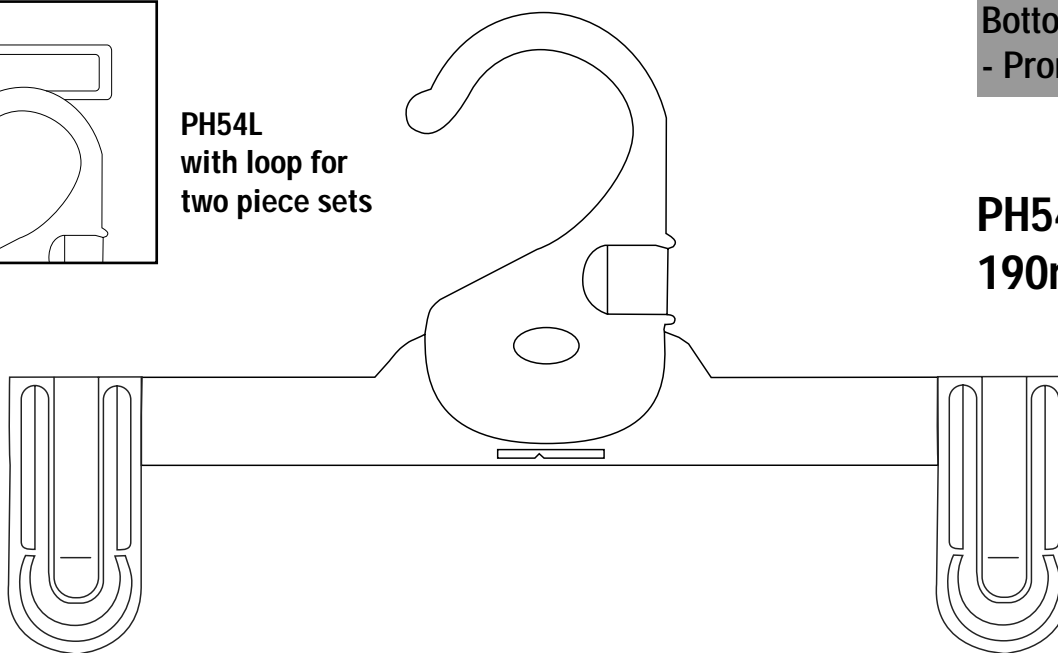

PH55L
with loop for
two piece sets

PH55
260mm

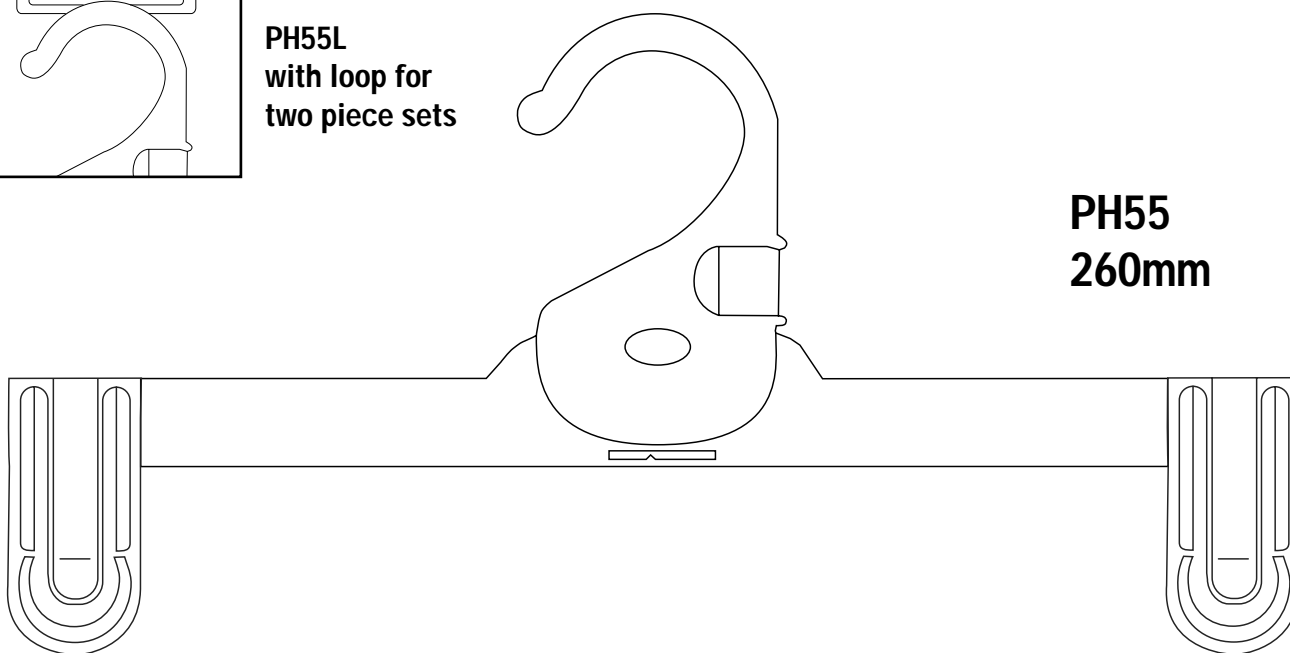

C O D E

FL57

FL58

FL59

Bottom Hanger
- Fox Lock

Category • Children, Adult

Application • Jeans, Pants, Skirts, Shorts, Mens Swimwear,
Pyjamas and Boxers

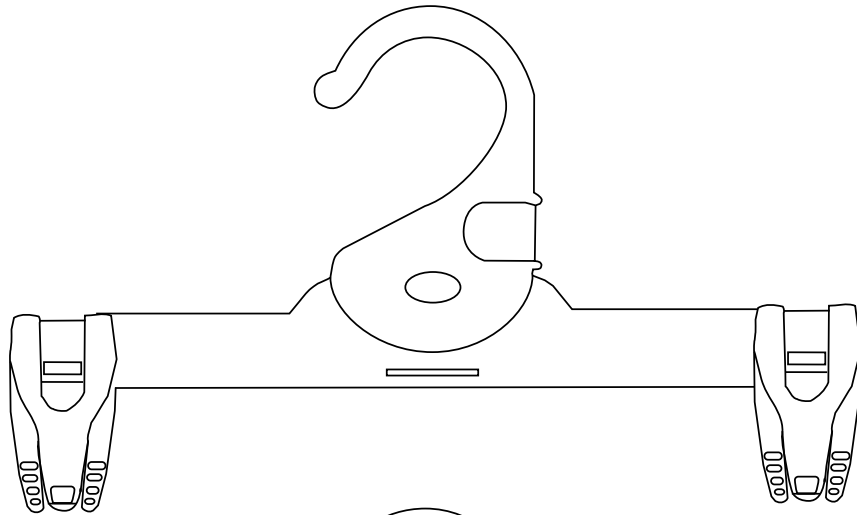

FL57
280mm

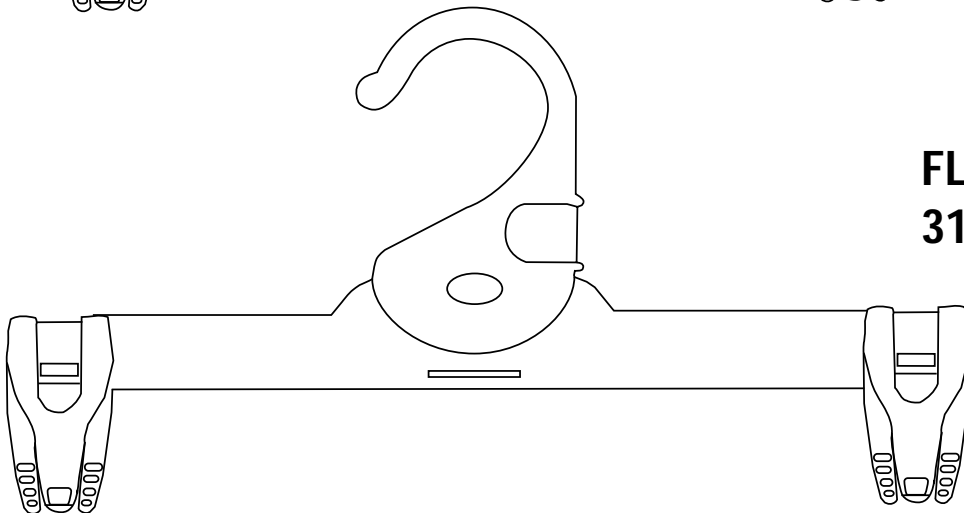

FL58
310mm

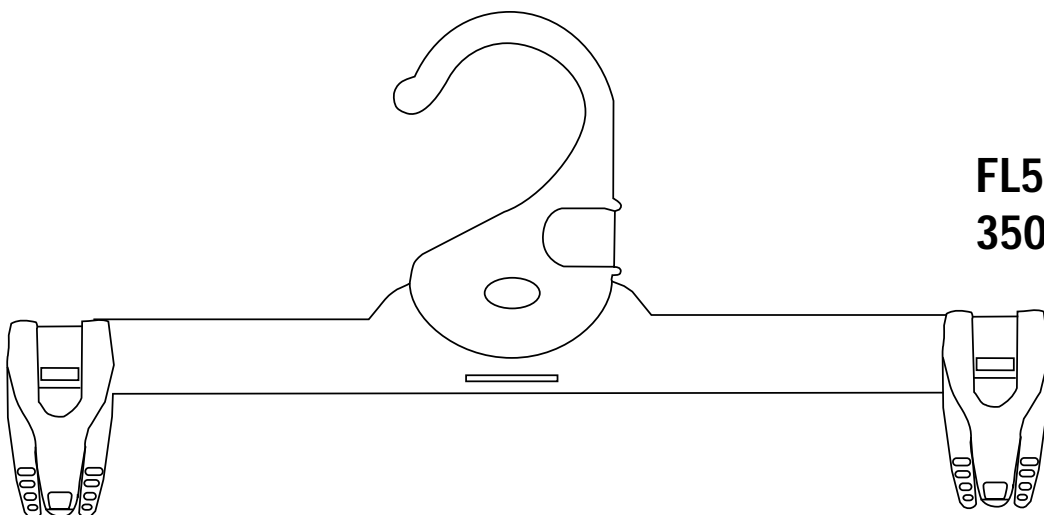

FL59
350mm

C O D E

Category • Children, Adult

Application • Pants, Skirts, Shorts and Sets

BH60

BH64

BH61

Bottom Hanger
Low Profile

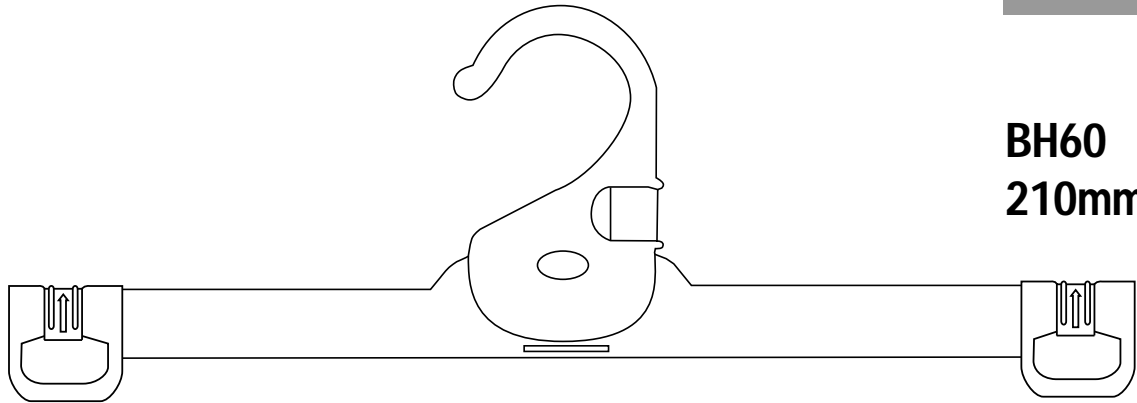

BH60
210mm

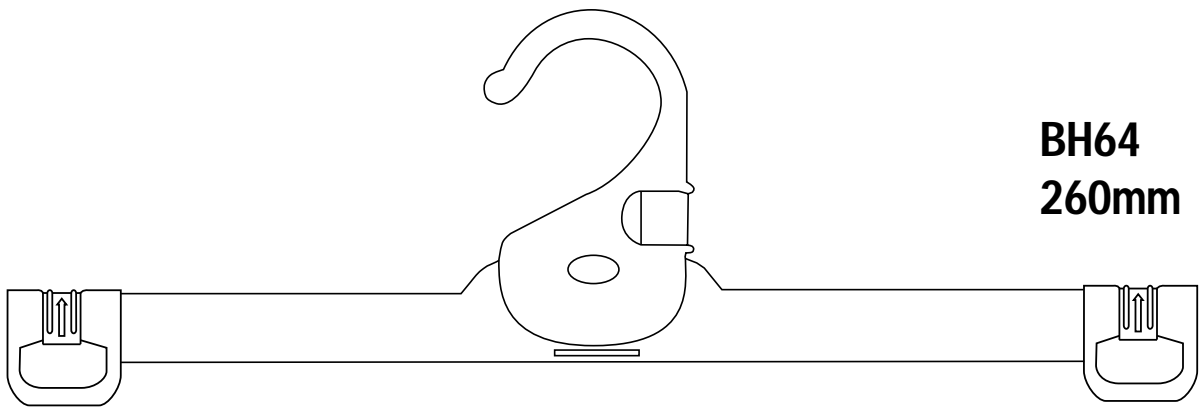

BH64
260mm

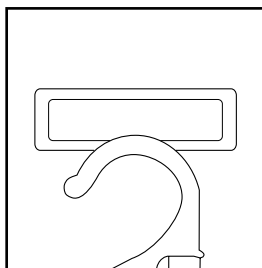

BH61L
with loop for
two piece sets

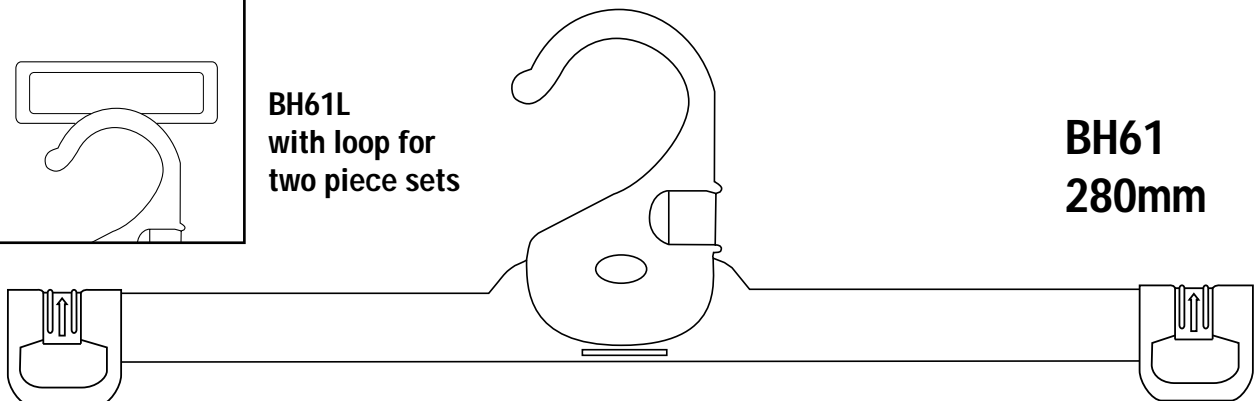

BH61
280mm

C O D E

Category • Adult

Application • Pants, Skirts, Shorts, etc

BH62

BH63

Bottom Hanger
Low Profile

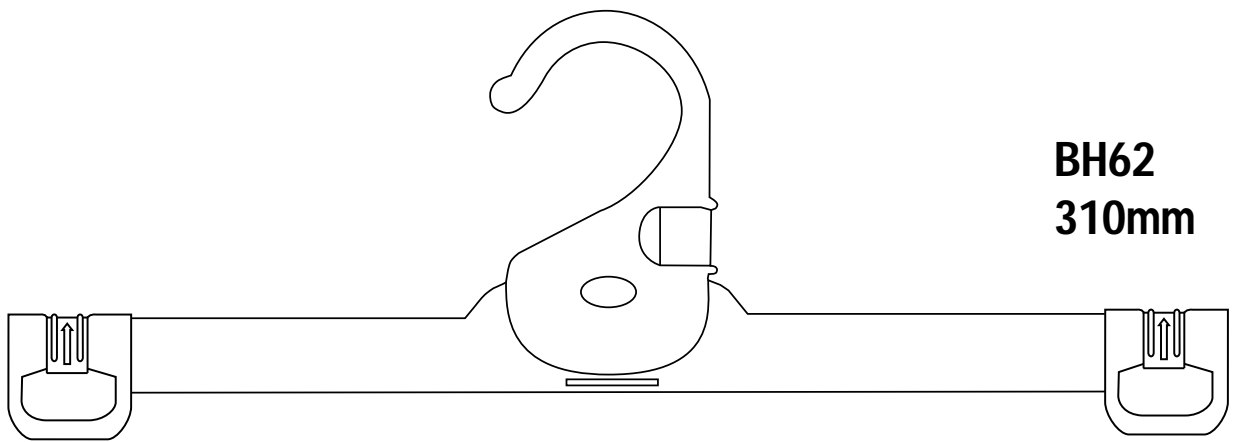

BH62
310mm

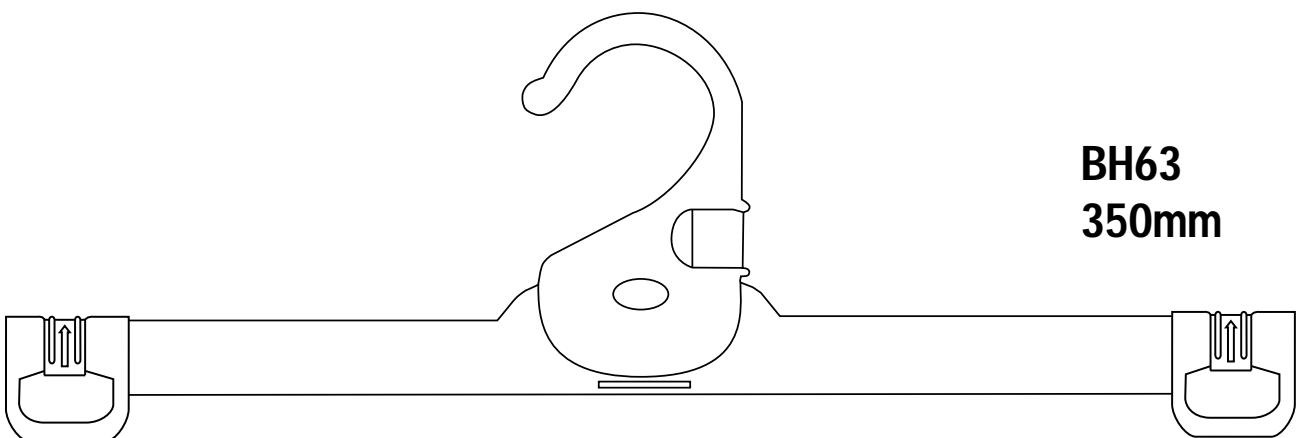

BH63
350mm

C O D E

AC16

Category • All

Application • All general purpose hangers
for outerwear and sleepwear

Size Clips



actual size

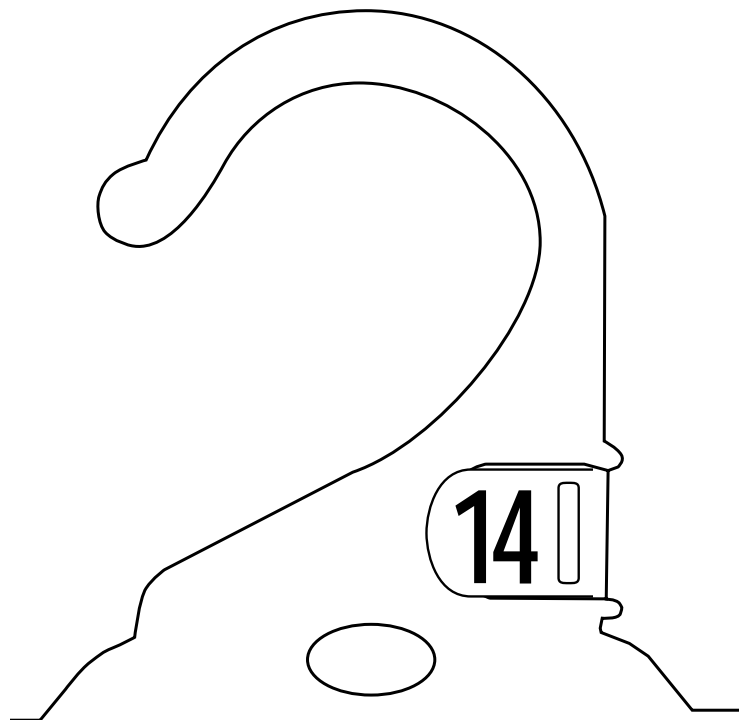

C O D E

LH34

LH35

LH76

Adult Brief
Hanger

Category • Childrens & Adult

Application • Briefs and Bras
(Black = Swimwear and Activewear)

LH35
200mm

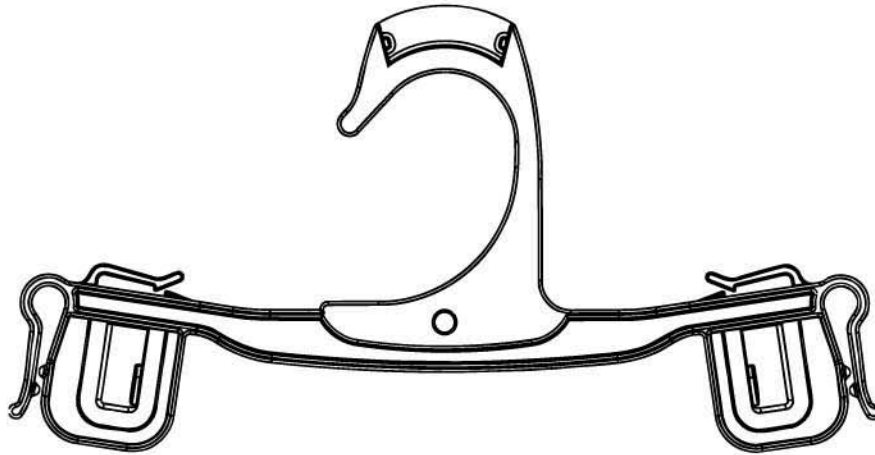

LH34
250mm

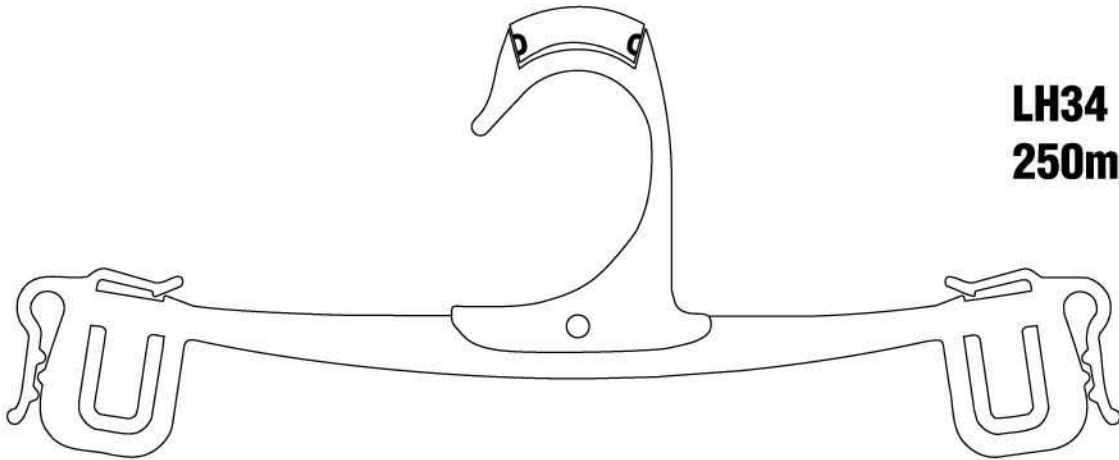

LH76
310mm

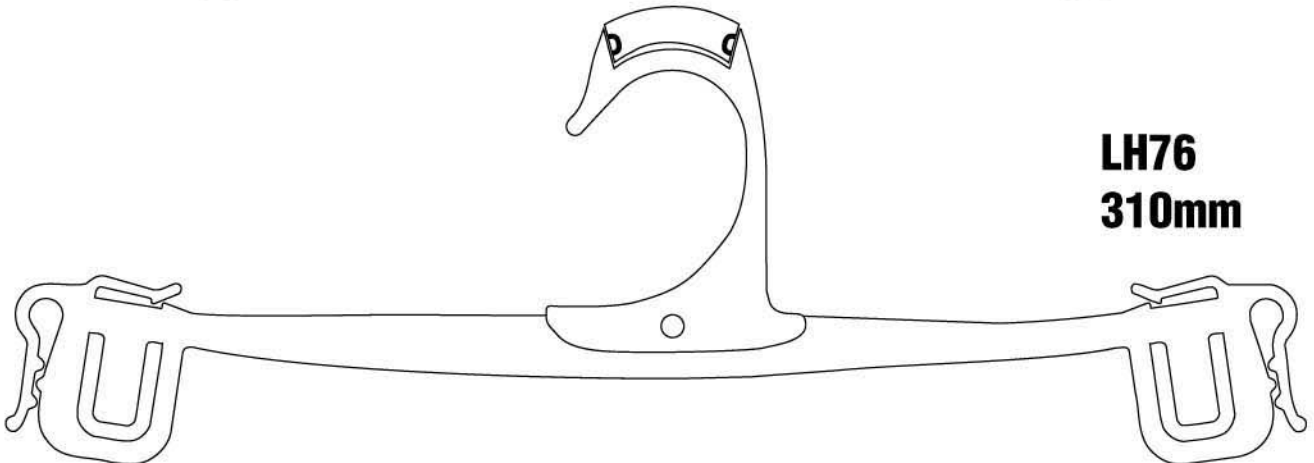

• LH35BL = BLACK

• LH34BL = BLACK
• LH34CR = CRYSTAL

• LH76BL = BLACK
• LH76CR = CRYSTAL

Category • Womens

Application • Bra's

C O D E

BR32CR

BR33CR

BraHanger

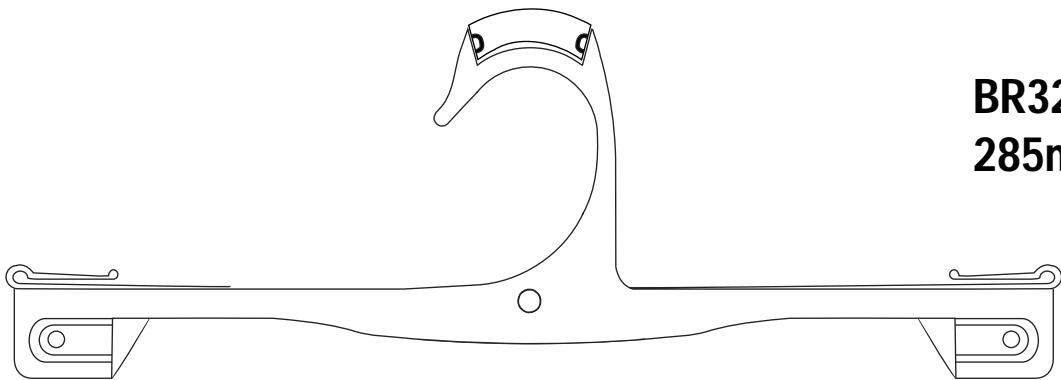

BR32CR
285mm

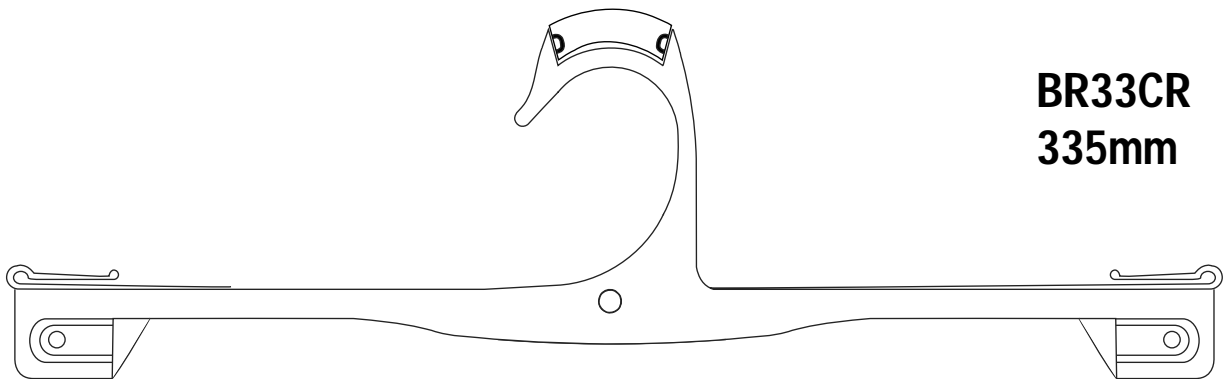

BR33CR
335mm

- BR32CR = CRYSTAL
- BR33CR = CRYSTAL

C O D E

AC22

Category • All

Application • Colour coded size inserts
for underwear and lingerie hangers

Lingerie
Sizing Insert

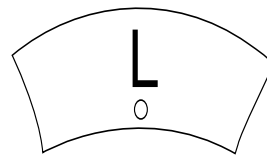

actual size

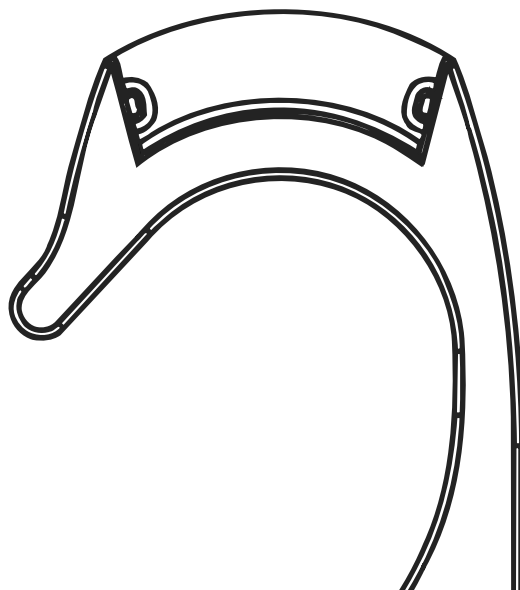

AC22 SIZE CLIP CHART - LINGERIE HANGERS ONLY

LADIESWEAR		
SIZE	PMS	COLOUR
4/6	264	Lilac
8A	359	Pale Green
8	359	Pale Green
10AA	154	Tan Brown
10A	154	Tan Brown
10	154	Tan Brown
10B	154	Tan Brown
10C	154	Tan Brown
10D	154	Tan Brown
10DD	154	Tan Brown
10E	154	Tan Brown
12AA	185	Red
12A	185	Red
12	185	Red
12B	185	Red
12C	185	Red
12D	185	Red
12DD	185	Red
12E	185	Red
14AA	279	Dark Blue
14A	279	Dark Blue
14	279	Dark Blue
14B	279	Dark Blue
14C	279	Dark Blue
14D	279	Dark Blue
14DD	279	Dark Blue
14E	279	Dark Blue
16A	264	Lilac
16	264	Lilac
16B	264	Lilac
16C	264	Lilac
16D	264	Lilac
16DD	264	Lilac
16E	264	Lilac
18	121	Yellow
18B	121	Yellow
18C	121	Yellow
18D	121	Yellow
18DD	121	Yellow
18E	121	Yellow

LADIESWEAR		
SIZE	PMS	COLOUR
20	347	Dark Green
20B	347	Dark Green
20C	347	Dark Green
20D	347	Dark Green
20DD	347	Dark Green
20E	347	Dark Green
22	444	Grey
22B	444	Grey
22C	444	Grey
22D	444	Grey
22DD	444	Grey
22E	444	Grey
24	164	Orange
24C	164	Orange
24D	164	Orange
24DD	164	Orange
24E	164	Orange
26	230	Pink
26D	230	Pink
26DD	230	Pink
26E	230	Pink
6/8	359	Pale Green
8/10	154	Tan Brown
10/12	185	Red
12/14	279	Dark Blue
14/16	264	Lilac
16/18	121	Yellow
18/20	347	Dark Green
20/22	444	Grey
22/24	164	Orange
24/26	230	Pink

CHILDRENSWEAR		
SIZE	PMS	COLOUR
000000	BLK	Black
00000	396	Lime
0000	318	Turquoise
000	347	Dark Green
00	164	Orange
0	264	Lilac
1	185	Red
2	121	Yellow
3	230	Pink
4	359	Pale Green
5	154	Tan Brown
6	264	Lilac
7	444	Grey
8	185	Red
9	230	Pink
10	279	Dark Blue
12	347	Dark Green
14	318	Turquoise
16	154	Tan Brown
2/3	230	Pink
3/4	359	Pale Green
4/6	264	Lilac
6/8	185	Red
8/10	279	Dark Blue
10/12	347	Dark Green
12/14	318	Turquoise
14/16	154	Tan Brown

MENSWEAR		
SIZE	PMS	COLOUR
75/80	347	Dark Green
85/90	PB	Proc Blue
95/100	375	Bright Green
105/110	154	Tan Brown
115/120	BLK	Black
125/130	MAG	Magenta
135/140	359	Pale Green
S	347	Dark Green
M	185	Red
L	PB	Proc Blue
XL	157	Brown
XXL	375	Bright Green
3XL	121	Yellow

Category • All

Application • Thongs

C O D E

FW24

Thong Hanger
115mm

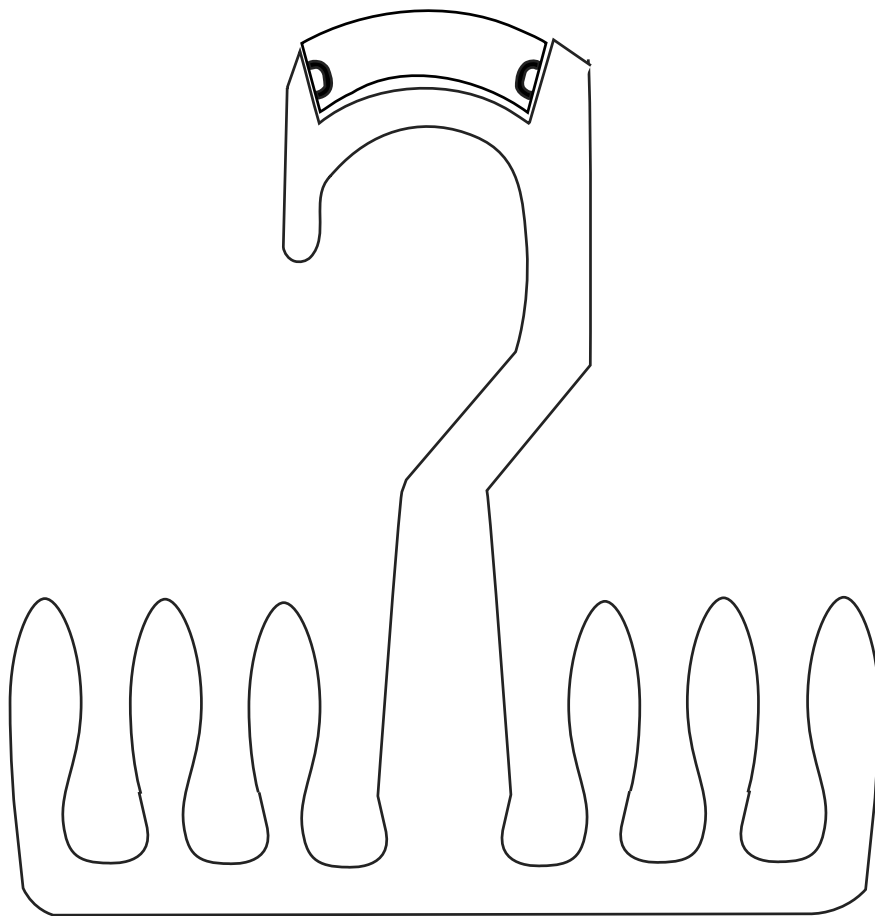

Category • Children, Adult

Application • Casual, Canvas and Court Shoes

C O D E

FW23

FW75

**Childrens
U End Hanger**

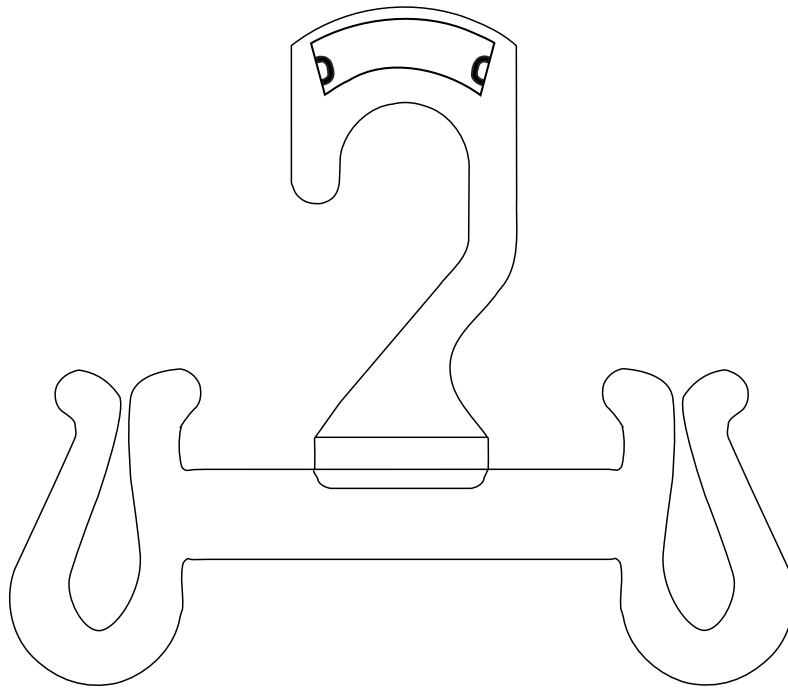

**FW23
70mm**

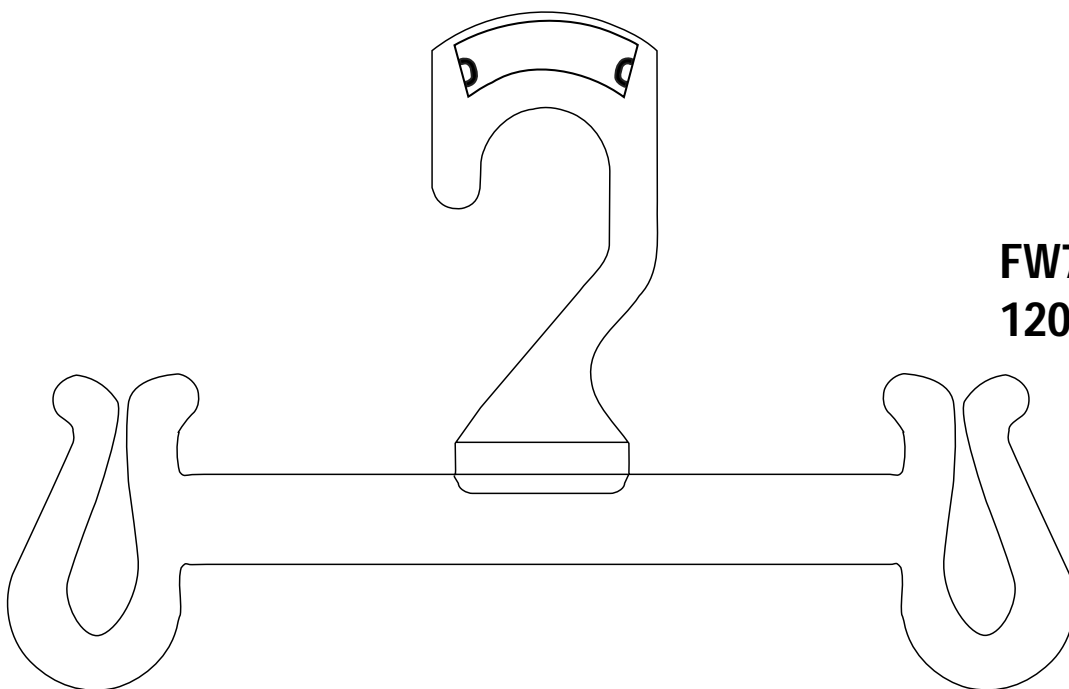

**FW75
120mm**

Category • All

Application • Shoes, Slippers and Scuffs

C O D E

FW25

FW77

FW26

Multi Purpose
Shoe Hanger

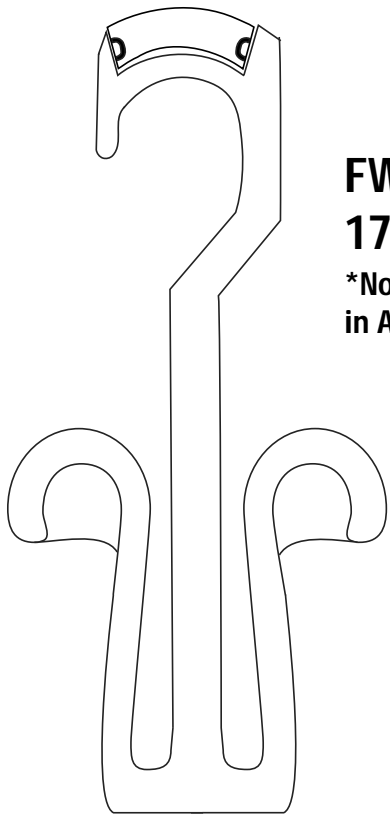

FW25
170mm

*Not available
in Australia

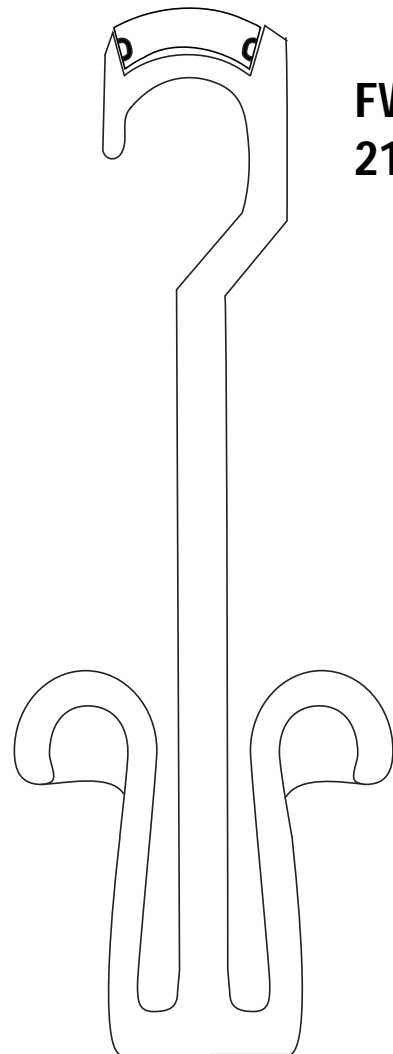

FW26
215mm

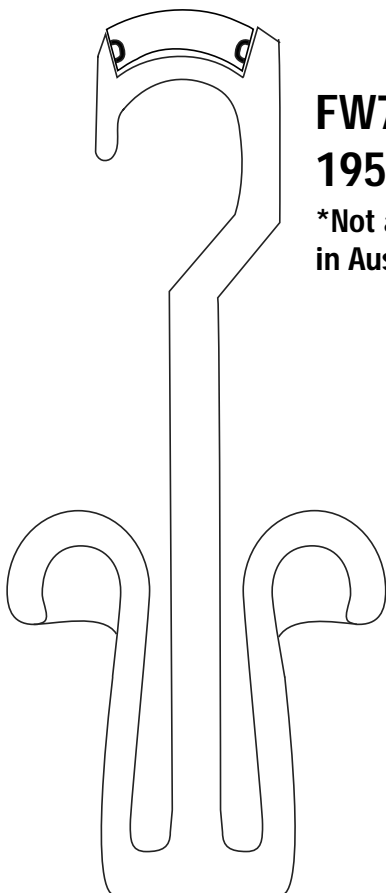

FW77
195mm

*Not available
in Australia

Category • All

Application • Colour coded size inserts for footwear

Sizing Insert
for Footwear

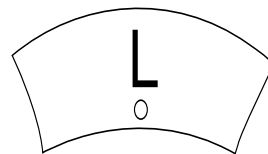

actual size

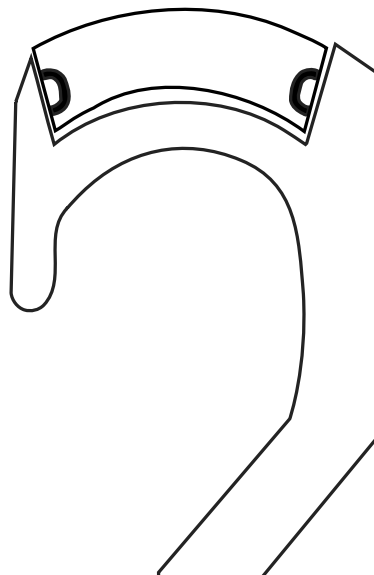

AC21 SIZE TAB CHART -SHOE HANGERS ONLY

GENERAL		
SIZE	PMS	COLOUR
1	185	Red
2	154	Tan Brown
3	264	Lilac
4	359	Pale Green
5	230	Pink
6	157	Brown
7	444	Grey
8	164	Orange
9	318	Turquoise
10	PB	Proc Blue
11	347	Dark Green
12	279	Dark Blue
13	121	Yellow
1/2	185	Red
2/3	154	Tan Brown
3/4	264	Lilac
4/5	359	Pale Green
5/6	230	Pink
6/7	157	Brown
7/8	444	Grey
8/9	164	Orange
9/10	318	Turquoise
10/11	PB	Proc Blue
11/12	347	Dark Green
12/13	279	Dark Blue
13/1	121	Yellow
S	347	Dark Green
M	185	Red
L	PB	Proc Blue
XL	157	Brown

Category • All

Application • Scarves, fine fabrics and wraps

C O D E

SC27

SC28

Scarf Hanger

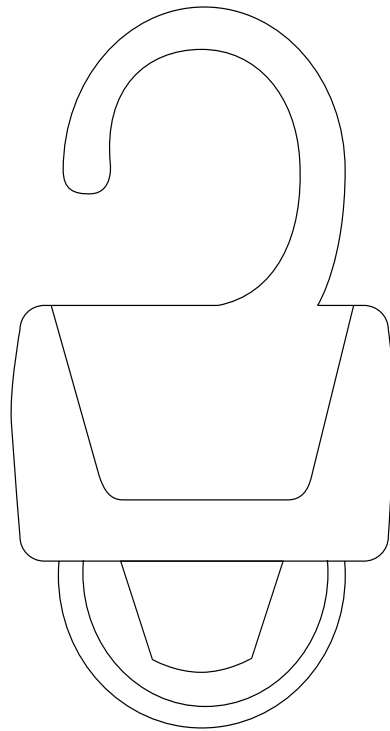

SC27
35mm

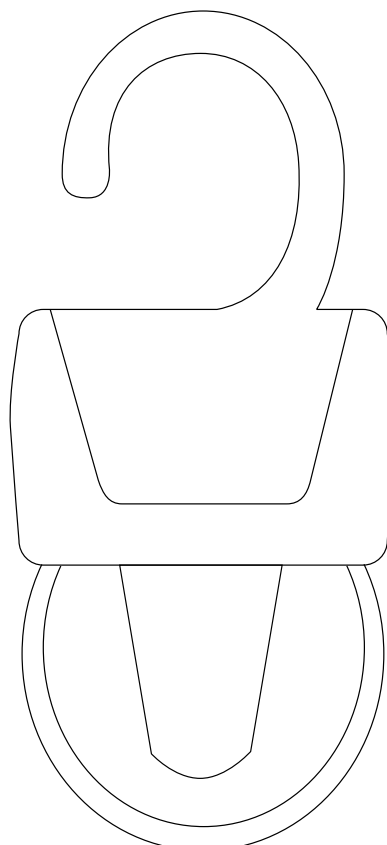

SC28
50mm

Category • All

Application • Totally interchangeable for all top and bottom hangers

Hook and Loop

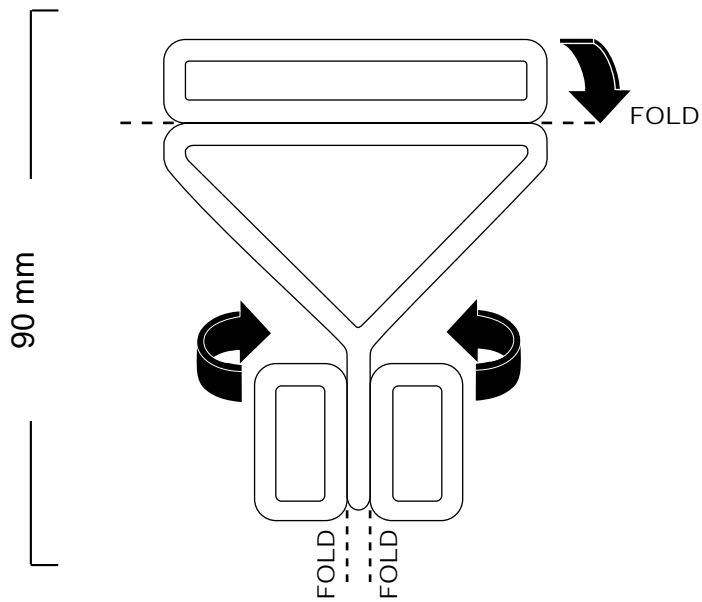

STEP 1

Fold clip at positions indicated

STEP 2

Place clip over tops hanger

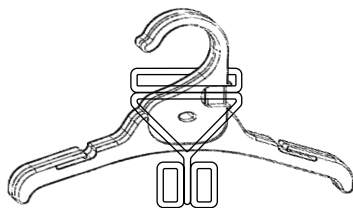

STEP 3

Place bottom hanger through both sections of lower clip

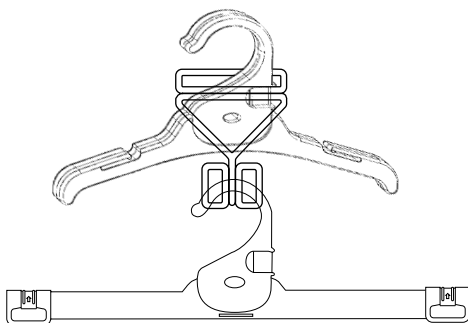

C O D E

AC66

AC69

Hook and
Loop

Category • All

Application • Totally interchangeable for all
top and bottom hangers

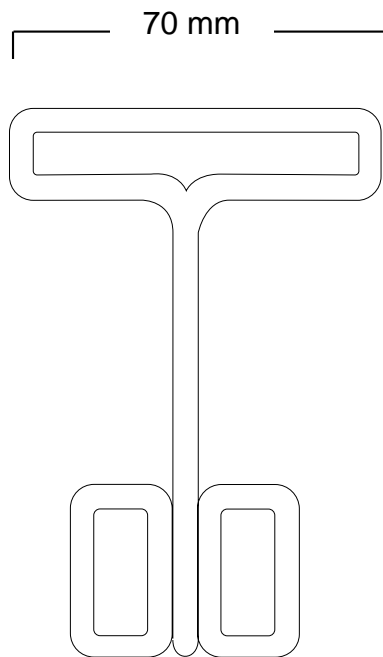

AC66
152mm

AC66
250mm

STEP 1

Place clip over tops hanger

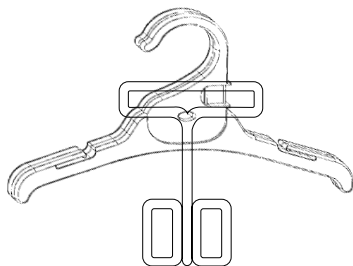

STEP 2

Place bottoms hanger through both
sections of lower clip

